

LANTERN Skylights



Our self supporting hipped lantern skylights incorporate structural aluminium ridge, hip and cill members and are secured to a flat-topped structural upstand curb. The curb must be supplied at least 100mm wide to accommodate our cill member.

We manufacture to any size from 1500mm to 5000mm in width and the skylights can be supplied in any length required. The glazed vertical upstands can range from 500mm to 1000mm deep.

Our pivoted cill member is designed to allow the skylight to be pitched at any angle starting at 15° up to a maximum of 45° and our standard pitches are available at increments of 5° within the range. Pitches exceeding 45° can still be supplied, but will require a modified cill member for this to be achieved.

The aluminium skylights are available in our Skyline and Skyline Box glazing systems and can be supplied in double glazed and single glazed options.

On larger skylights we install stainless steel tension wires at the curb positions at approximately three metre intervals along the ridge line to prevent the horizontal loadings being transferred to the builders curb.

All our Skylights are fully assembled in our factory during manufacture to ensure a perfect fit with no site cutting necessary.

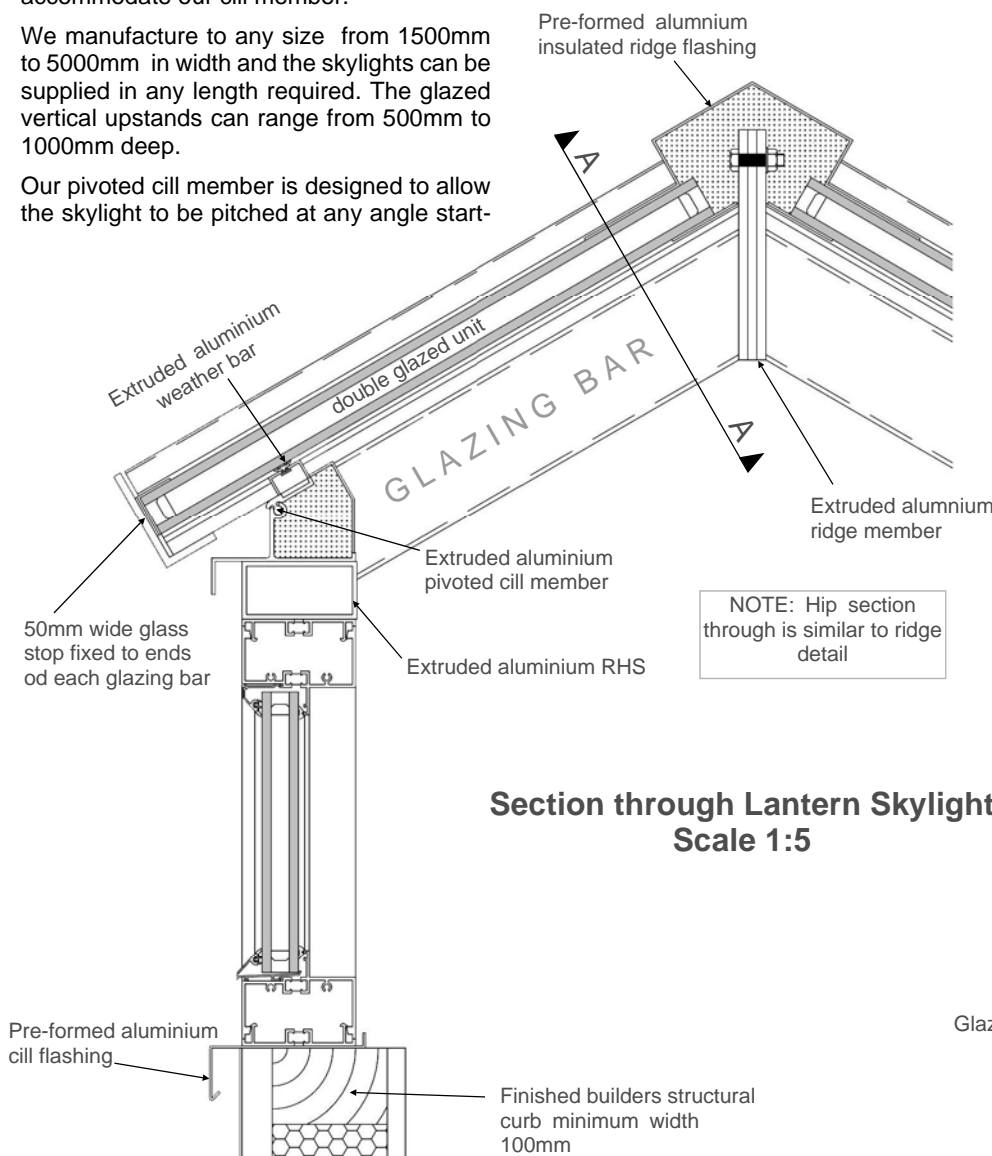

Section through Lantern Skylight Scale 1:5

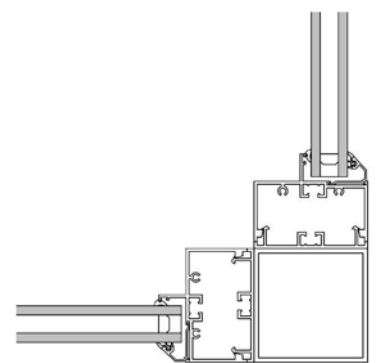

Section at corner post

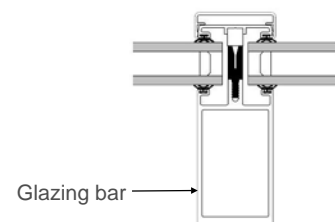

Section A-A